

DIMENSIONS

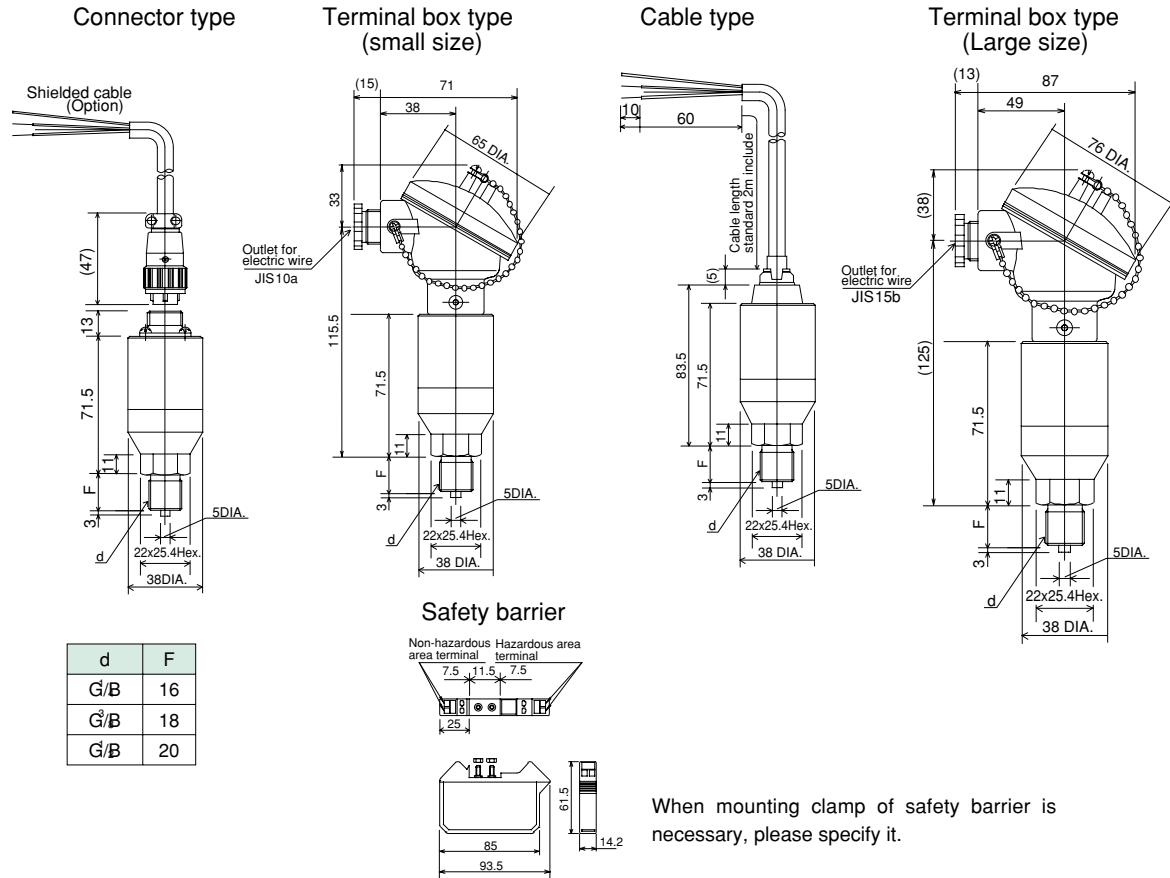

INTRINSICALLY SAFETY EXPLOSION-PROOF

The intrinsically safety explosion proof class authorization:

Type name	Type approval number
K J 1 5 - 0 Transmitter K J 1 5 Safety barrier M T L 7 8 8 +	4 0 3 1 7

Intrinsically safe explosion-protected construction:

The intrinsically safe explosion-protection construction means a construction in which it is verified by the ignition test or others conducted by a public authority that any spark or high temperature part produced either normally or in a specific fault condition is incapable of igniting explosive.

Hazardous areas:

Zone 0 or zone 1, zone 2

Classification of hazardous areas:

Hazardous area	Contents
Zone 0	A place where hazardous atmosphere is continuously present or present for a long period under ordinary circumstances.
Zone 1	A place where hazardous atmosphere is likely to occur under ordinary circumstances.
Zone 2	A place where hazardous atmosphere is likely to occur under abnormal circumstances.

WIRING

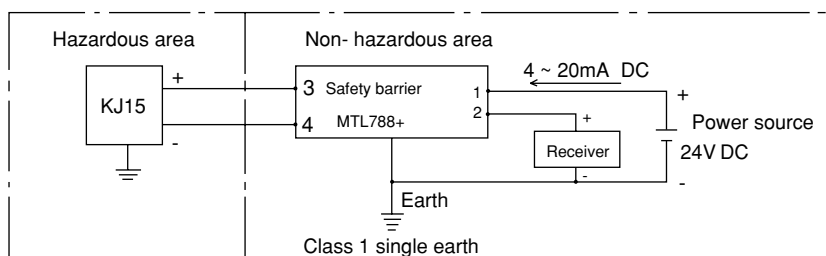

Type No. constitution

Please specify Type No., each specification and range when ordering.

Note: For this Model, there is no applicable item for the figures X, but please specify X when ordering.

