



Glycerine Bath Type Pressure Gauges

OUTLINE

This is a gauge for exclusive use exposed to vibration. Its interior is filled with liquid, preventing vibration of moving parts and wear of interior linkage mechanism, and making maintenance work easier.

FEATURES

- The wetted parts and the case are made of stain less steel so that they are excellent in anti-corrosion and enviromental resistance.
- By equipping a blowout disk, the effect of temperature change on accuracy is reduced, and breakage of glass is prevented in case the Bourdon tube bursts.
- To indicate the working pressure, safety mark(green mark) can be provided with an arrow mark only for 60mm and 75mm gauge as an option.

* In case of selecting pressure gauge, choose the pressure range which can be used in between 30~65% of full scale,so that the gauge can give its full capacity.

* Also should be confirmed whether the wetted parts material is suitable for the fluid or not.

SPECIFICATION

Fluid:

Gas or liquid

Size :

60 DIA., 75 DIA., 100 DIA., 150 DIA.

Mounting:

Stem.....



Type A



Type B(Mounting hole)

Panel.....



Type D(Mounting clamp, online)

Connection:

G1/4B(PF), G3/8B(PF), G1/2B(PF),
1/2NPT, 1/4NPT, R1/4(PT),
R3/8(PT), R1/2(PT)

* For other connections, please contact us.

Wetted parts material:

Bourdon tube 316 st.st.
Socket 316 st.st.

Pressure range:

0 ~ 0.1 → 0 ~ 200MPa (0 ~ 1 → 0 ~ 2000kgf/cm²)
-0.1 ~ 0 → -0.1 ~ 2MPa
(76cmHg ~ 0kgf/cm² → 76cmHg ~ 20kgf/cm²)

Operating temperature:

-5 ~ 40°C

Accuracy :

±1.5%F.S.

Window:

Inorganic glass (60 DIA.),
Acrylic glass (75 DIA.,100 DIA.,150 DIA.)

The filling up liquid:

Glycerine
(For range, less than 0.4MPa and its compound, glycerine solution in water is used.)

Case material finishing:

304 st.st.

Treatment: (Option)

Use no oil-water

Dial scale specified: (Option)

Capacity scale, Dual scale , Printed words,
Colored circle

Caution of operation:

It is established the air circulation hole in case upper part to prevent indication error by ambient temperature change about pressure gauge / compound pressure gauge / vacuum gauge less than maximum pressure 1MPa. Do up yellow plug of relief valve up.

And installation posture limit it to vertical installation.

DIMENSION 1 (Unit:mm)

100 DIA.

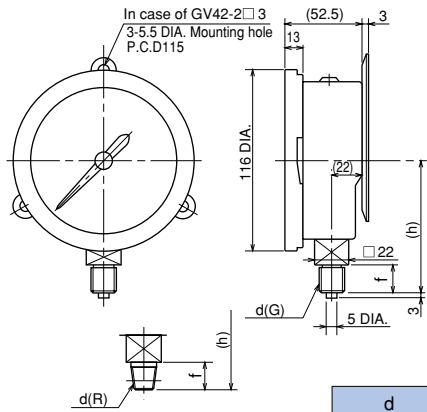

GV42-□□3

d	h	f
G3/8B	86	18
R3/8	86	18
G1/2B	88	20
R1/2	88	20

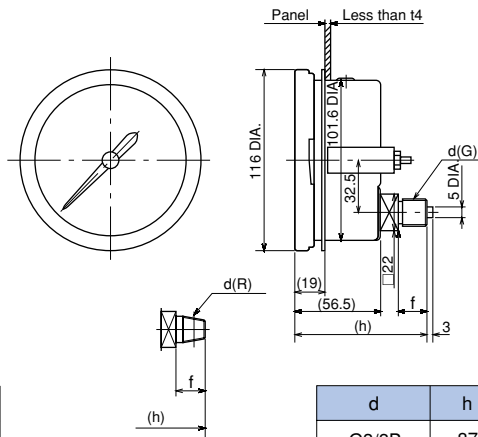

GV47-1□□3

d	h	f
G3/8B	87	18
R3/8	87	18
G1/2B	89	20
R1/2	89	20

60 DIA.

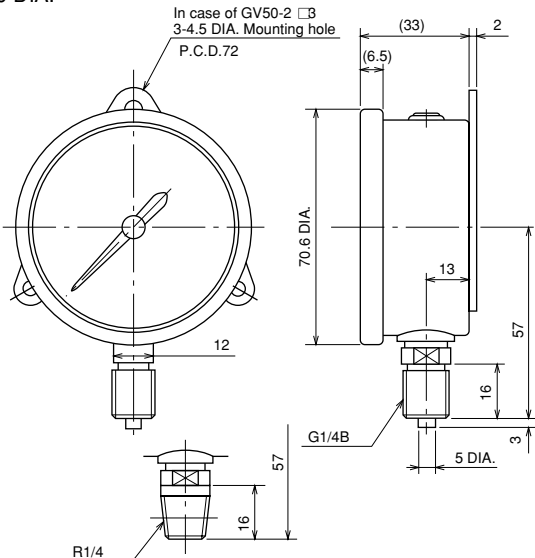

GV50-□□3

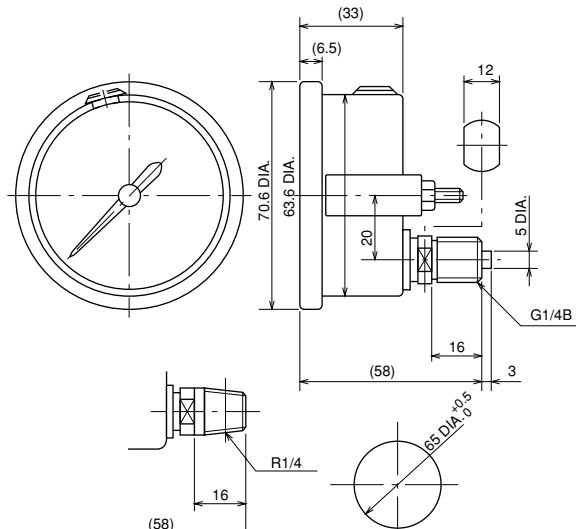

GV55-1□□3

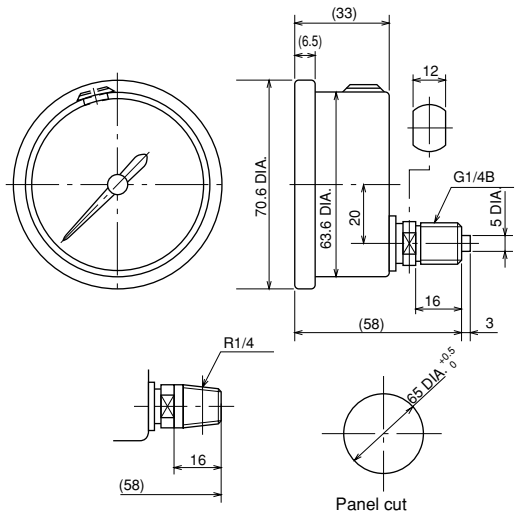

GV55-6□□3

DIMENSION 2 (Unit:mm)

75 DIA.

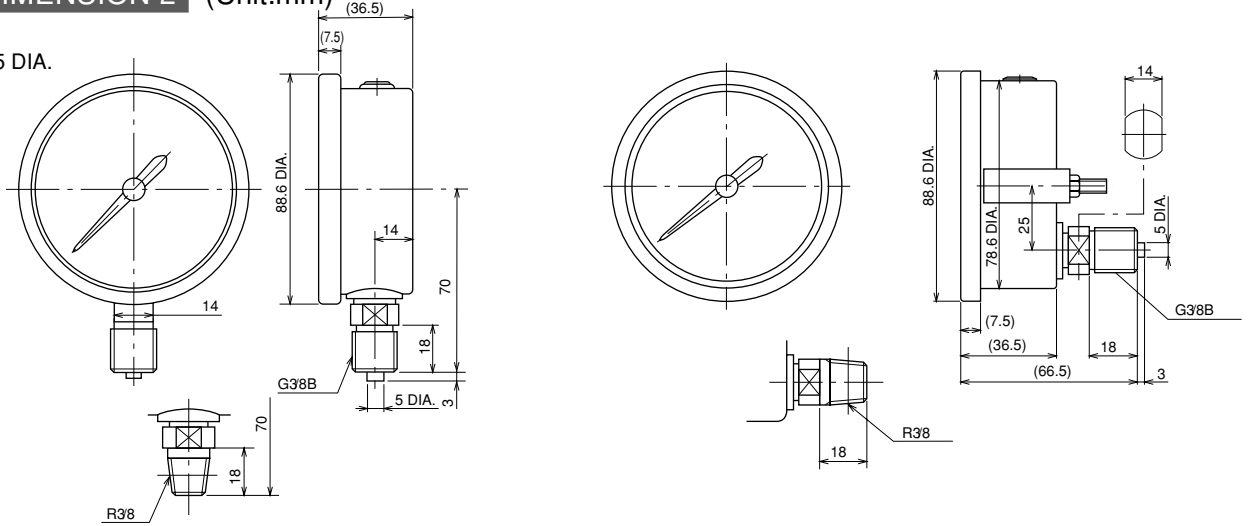

GV51-1□3

GV56-1□□

150 DIA.

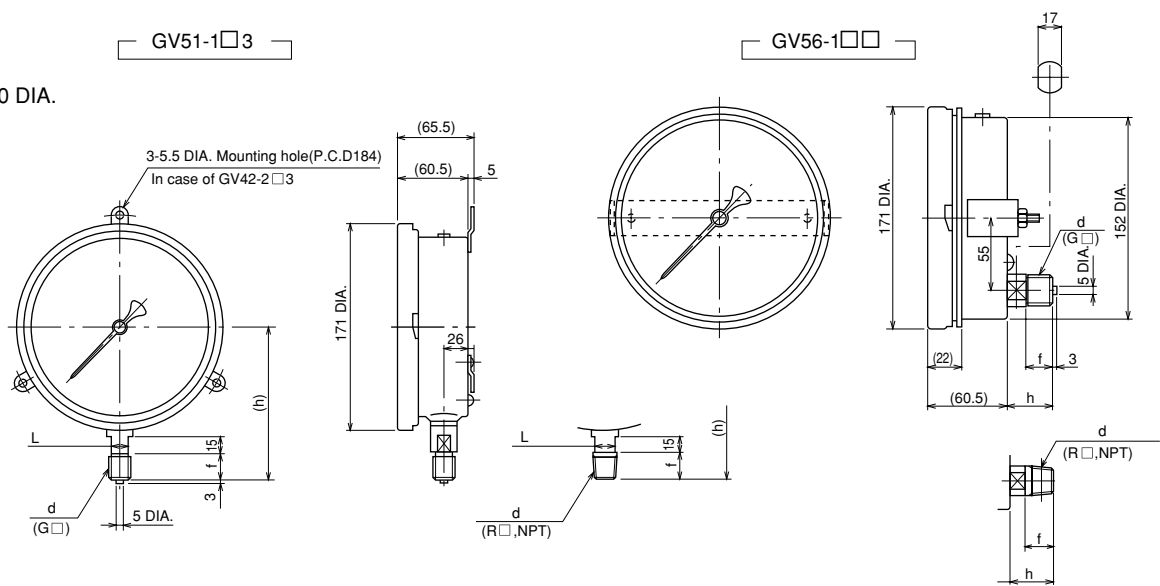

GV44-□□3

GV49-1□3

d	f	h	L
G3/8B	18	123	14
G1/2B	20	125	17
1/2NPT	20	125	17
R3/8	18	123	14
R1/2	20	125	17

d	f	h
G3/8B	18	30
G1/2B	20	32
1/2NPT	20	32
R3/8	18	30
R1/2	20	32

Throttle: (option)

For reducing pulsating pressure,throttle is put on the inlet port.

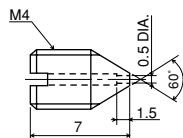

Corrosion-proof use FS10-013
Material: 316 st.st.

SETTING METHOD OF SAFETY MARK

Color of safety mark (option) is green and movable to any place.

Indication of pressure setting location	Set the 2pcs. of safety mark together.	
Indication of pressure setting range.	Set the safety mark at high and low set point.	

Type No. constitution

Please specify Type No., each specification and range, when ordering.

Note: For this Model, there is no applicable item for the figures X, but please specify X when ordering.

Size	Weight																														
100 DIA. In throttle	<table border="1"> <tr> <td>G</td><td>V</td><td>4</td><td>2</td> <td>Stem</td> <td>1</td> <td>Type A</td> <td rowspan="2">Approx. 1kg</td> </tr> <tr> <td></td><td></td><td></td><td></td> <td></td> <td>2</td> <td>Type B</td> </tr> <tr> <td></td><td></td><td></td><td></td> <td>Panel</td> <td>1</td> <td>Type D(Mounting clamp)</td> <td>Approx. 1kg</td> </tr> </table>	G	V	4	2	Stem	1	Type A	Approx. 1kg						2	Type B					Panel	1	Type D(Mounting clamp)	Approx. 1kg							
G	V	4	2	Stem	1	Type A	Approx. 1kg																								
					2	Type B																									
				Panel	1	Type D(Mounting clamp)	Approx. 1kg																								
150 DIA. In throttle	<table border="1"> <tr> <td>G</td><td>V</td><td>4</td><td>4</td> <td>Stem</td> <td>1</td> <td>Type A</td> <td rowspan="2">Approx. 2.5kg</td> </tr> <tr> <td></td><td></td><td></td><td></td> <td></td> <td>2</td> <td>Type B</td> </tr> <tr> <td></td><td></td><td></td><td></td> <td>Panel</td> <td>1</td> <td>Type D(Mounting clamp)</td> <td>Approx. 2.5kg</td> </tr> </table>	G	V	4	4	Stem	1	Type A	Approx. 2.5kg						2	Type B					Panel	1	Type D(Mounting clamp)	Approx. 2.5kg							
G	V	4	4	Stem	1	Type A	Approx. 2.5kg																								
					2	Type B																									
				Panel	1	Type D(Mounting clamp)	Approx. 2.5kg																								
60 DIA.	<table border="1"> <tr> <td>G</td><td>V</td><td>5</td><td>0</td> <td>Stem</td> <td>1</td> <td>Type A</td> <td rowspan="2">Approx. 0.3kg</td> </tr> <tr> <td></td><td></td><td></td><td></td> <td></td> <td>2</td> <td>Type B</td> </tr> <tr> <td></td><td></td><td></td><td></td> <td>Panel</td> <td>1</td> <td>Type D(Mounting clamp)</td> <td rowspan="2">Approx. 0.3kg</td> </tr> <tr> <td></td><td></td><td></td><td></td> <td></td> <td>6</td> <td>Type D(On line)</td> </tr> </table>	G	V	5	0	Stem	1	Type A	Approx. 0.3kg						2	Type B					Panel	1	Type D(Mounting clamp)	Approx. 0.3kg						6	Type D(On line)
G	V	5	0	Stem	1	Type A	Approx. 0.3kg																								
					2	Type B																									
				Panel	1	Type D(Mounting clamp)	Approx. 0.3kg																								
					6	Type D(On line)																									
75 DIA.	<table border="1"> <tr> <td>G</td><td>V</td><td>5</td><td>1</td> <td>Stem</td> <td>1</td> <td>Type A</td> <td rowspan="2">Approx. 0.4kg</td> </tr> <tr> <td></td><td></td><td></td><td></td> <td></td> <td>2</td> <td>Type B</td> </tr> <tr> <td></td><td></td><td></td><td></td> <td>Panel</td> <td>1</td> <td>Type D(Mounting clamp)</td> <td>Approx. 0.4kg</td> </tr> </table>	G	V	5	1	Stem	1	Type A	Approx. 0.4kg						2	Type B					Panel	1	Type D(Mounting clamp)	Approx. 0.4kg							
G	V	5	1	Stem	1	Type A	Approx. 0.4kg																								
					2	Type B																									
				Panel	1	Type D(Mounting clamp)	Approx. 0.4kg																								

Model: GV 1 2 3 4 5 6 7 8 9 10 11 12 13 14 15

Glycerine bath type pressure gauge

Type No. 3

Selection spec. 0 0 0

Additional spec.(Option) X X X X

2 Connection

	GV42-47	GV44-49	GV50-55	GV51-56
2 G1/4B	—	—	○	—
3 G3/8B	○	○	—	○
4 G1/2B	○	○	—	—
5 1/4NPT	—	—	○	—
6 1/2NPT	○	○	—	—
7 R1/4	—	—	○	—
8 R3/8	○	○	—	○
9 R1/2	○	○	—	—

3 Wetted parts material

3 Bourdon tube:316 st.st.
Socket:316 st.st.

4 Pressure range(MPa)
(When ordering, please specify pressure range & unit.)

1	-0.1~0.1, 0.2, 0.3, 0.4, 0.6 -0.1~1, 1.5, 2
2	0~0.1, 0.2, 0.3, 0.4, 0.6 0~1, 1.5, 2, 2.5, 3.5 -0.1~0
3	0~5, 7, 10
4	0~15, 25, 35
5	0~50, 70
6	0~100
7	0~150, 200

Applicable GV42-47 only

5 Accuracy

0 Standard(±1.5%F.S.)

6 Pointer

0 Standard

7 Window

0 GV42-47-44-49-51
56:Acrylic glass(Std.)
GV50-51:Inorganic glass

8 Treatment

0 Nil
1 Use no oil
2 Use no water
3 Use no oil-water

9 Throttle For GV4

X Complete with FS10-013(Standard)

9 Throttle For GV5

0 Nil
1 FS10-013

10 Other additional spec.

0 Nil
1 Please specify your requirement
Dial scale specified
Safety mark include
(Available GV5 only)

15 Document

0 Nil
1 Please specify your requirement
Drawing one sheet, Instruction manual
Inspection procedure, Mill sheet
Test report

The contents in the catalogue are subject to change without notice.

NAGANO KEIKI CO., LTD.



UEDA FACTORY (JQA-0794)
MARUKO FACTORY (JQA-0789)

HEAD OFFICE & OVERSEAS : 1-30-4, HIGASHIMAGOME OHTA-KU, TOKYO, JAPAN.
TELEPHONE : 03 (3776) 5328
SALES DEPT FAX : 03 (3776) 5447
TELEX : 2468452 NKSTKY J

OVERSEAS PLANTS
OR AFFILIATES: U.S.A., KOREA, GERMANY
OVERSEAS SALES NETWORK: AUSTRALIA, HONG KONG, INDONESIA,
KOREA, MALAYSIA, PHILIPPINES,
SINGAPORE, TAIWAN, THAILAND, U.S.A.