



CQ20 Pressure Switch

OUTLINE

This is a pressure switch in which a Bourdon tube is applied to the pressure sensing element. The move of the Bourdon tube directly activates the microswitch, turning on and off the circuit. This switch is appropriate for the pressure control of air pressure, water pressure, oil pressure, etc. for liquid level control, flow control, etc.

FEATURES

- As this switch is of microswitch type, stable turning on and off operation is assured by snap action.
- This switch demonstrates excellent vibration resistance, and can be directly attached to equipment as a job site type.

* In case of selecting pressure gauge, choose the pressure range which can be used in between 30 ~ 65% of full scale, so that the gauge can give its full capacity.

SPECIFICATION 1

Fluid:

Gas or liquid

Operating condition:

Under the normal condition, where there is no inflammable gas or liquid which cause the ignition or explosion.

Mounting:

Stem, panel

Connection:

G3/8B(PF), G1/2B(PF), R3/8(PT), R1/2(PT),
3/8NPT, 1/2NPT

Wetted parts material:

General use

Bourdon tube 316st.st.

Socket YBsC3

* Applicable to 35MPa range

Corrosion-proof

Bourdon tube 316st.st.

Socket SCS14

Pressure range:

0 ~ 0.1 → 0 ~ 70MPa (0 ~ 1 → 0 ~ 700kgf/cm²)

-0.1 ~ 0MPa (-1 ~ 0kgf/cm²)

* 20 ~ 100kPa (receiver) is available, contact NKS for details.

Proof-pressure:

150% of pressure range

Recommended setting range:

15 ~ 90% of pressure range

Operating temperature:

-20 ~ 60°C

Accuracy:

1% max. P.

Setting accuracy:

±3% max. P.

Temperature coefficient:

0.05% max. P./°C

Dead band:

Fixed 0.01 ~ 3.1MPa or less (0.1 ~ 31kgf/cm²)
(Depending on range)

Switch:

JIS C4505 Industrial microswitch

Number of contact :

One contact

Setting system:

External adjustment type

Outlet for electric wire:

Gland JIS 10b

Case material-finishing:

Aluminium alloy die casting (ADC12)-Black

Construction:

IP42

Weight:

Approx. 1kg

SPECIFICATION 2

Pressure range & dead band:

Pressure range MPa(kgf/cm ²)	Dead band MPa(kgf/cm ²)	Pressure range MPa(kgf/cm ²)	Dead band MPa(kgf/cm ²)
-0.1~0 (-1~ 0)	0.01 or less(0.1)	0~2.5 (0~ 25)	0.15 or less(1.5)
		~3.5 (~ 35)	0.14 (1.4)
0~0.1 (0~ 1)	0.01 (0.1)	~5 (~ 50)	0.175 (1.75)
~0.2 (~ 2)	0.016 (0.16)	~7 (~ 70)	0.24 (2.4)
~0.3 (~ 3)	0.024 (0.24)	~10 (~ 100)	0.65 (6.5)
~0.4 (~ 4)	0.024 (0.24)	~15 (~ 150)	0.52 (5.2)
~0.6 (~ 6)	0.039 (0.39)	~25 (~ 250)	1.25 (12.5)
~1 (~10)	0.06 (0.6)	~35 (~ 350)	1.05 (10.5)
~1.5 (~15)	0.068 (0.68)	~50 (~ 500)	2.2 (22.0)
~2 (~20)	0.08 (0.8)	~70 (~ 700)	3.1 (31.0)

Electric characteristics:

	Rating		Withstand voltage	Insulation resistance
	Load resistance	Inductive load		
125V AC	15A	15A	1500V AC Between terminal and case 1 minute	500V DC 100MΩ over Between terminal and case
250V AC	15A	15A		
30V DC	2A	1A		
125V DC	0.5A	0.05A		
· Inductive load: Power factor more 0.4 (AC) Time-contact 7ms or less (DC)				

DIMENSIONS

Stem

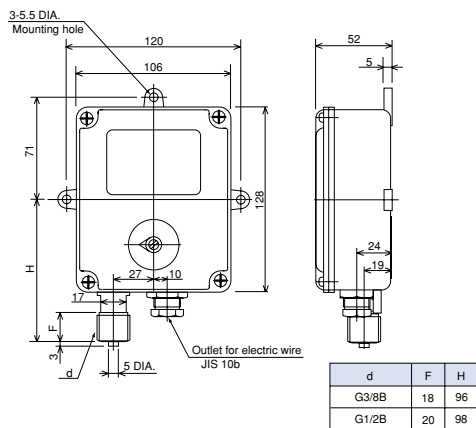

Panel

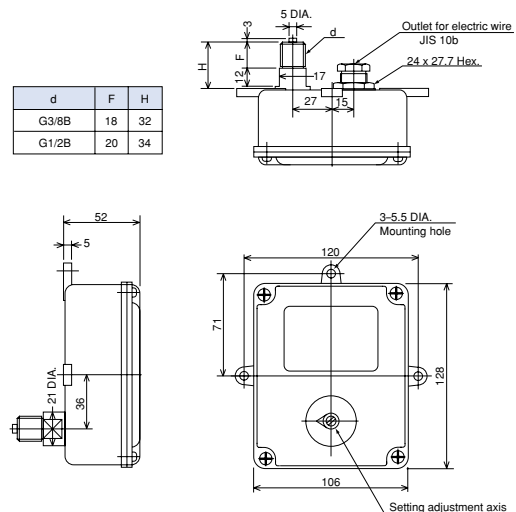

REMARKS

- As a sequencer input;
Use this switch in the ventilated condition.
Otherwise the following might be caused.
The contact resistance of the microswitch increases gradually as time passes.
For the application in the atmosphere, especially including Si, SiO₂ will be accumulated on the contact part as switch operated. Then the contact resistance will be increased, so that switch may be not operated.
Therefore, above is suggested for the application condition, including Si atmosphere.
When you use this switch as sequencer input for controlling, input or connect through 100V AC Relay.
- Installation of protection circuit for contact
In the inductive load open and close circuit, install the protection circuit to protect the contact.
When you use the relay, choose the built-in protection circuit for the contact.

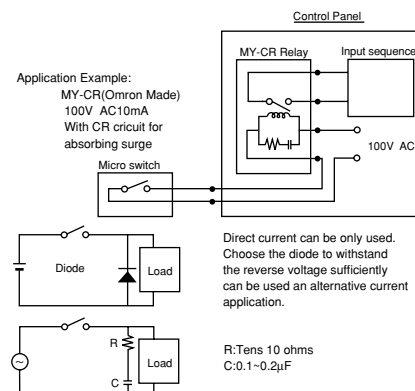

Type No. constitution

Please specify Type No., each specification and range when ordering.

Note: For this Model, there is no applicable item for the figures X, but please specify X when ordering.

Pressure switch
C Q 2 0 — 1 2 3 — 4 5 6 7 **2** 8 9 10 11 12 13 14 15

Type No.

Selection spec.

Additional spec.(Option)

1 Type

3	Stem
7	Panel

2 Mounting

3	G3/8B
4	G1/2B
G	R3/8
H	R1/2
L	3/8NPT
M	1/2NPT

3 Wetted parts material

1	Bourdon tube:316 st.st. Socket:YBsC3 Applicable to 35MPa range
3	Bourdon tube:316 st.st. Socket:SCS14

4 Pressure range (MPa)

(When ordering, please specify pressure range & unit.)

1	-0.1 ~ 0
2	0 ~ 0.1, 0.2, 0.3, 0.4
3	0 ~ 0.6, 1, 1.5, 2, 2.5, 3.5, 5, 7
4	0 ~ 10, 15, 25, 35
5	0 ~ 50, 70

5 Type of contact

1	H : Upper limit type with one contact
2	L : Lower limit type with one contact

6 Power

0	Standard type
1	Ultra high sensitivity switch
3	Standard + gold plated
4	Ultra high sensitivity switch + gold plated

7 Outlet for electric wire

2	Gland JIS 10b
---	---------------

8 Treatment

0	Nil
1	Use no oil
2	Use no water
3	Use no oil-water

9 Other additional spec.

0	Nil
1	Please specify your requirement The center back socket, Case finishing

10 X

11 X

12 X

13 X

14 X

15

15 Document

0	Nil
1	Please specify your requirement Drawing one sheet, Instruction manual, Inspection procedure, Mill sheet, Test report