



Model KL77 Ceramic Capacitance Sensor

OUTLINE

This is a ceramic capacitance sensor with a Teflon coated, corrosion-resistant ceramic diaphragm at the pressure-sensing portion, and can be applied to pressure gauges in the field of micropressure and low pressure.

FEATURE

- * High corrosion resistance has been realized by applying Teflon(FEP)coating to the sensor pressure sensing portion, Teflon (PTFE) to the housing and connecting screws, fluorine rubber(FPM)to the sealing
- * This ceramic capacitance sensor can be applied to the semiconductor manufacturing apparatus, medical equipment, liquid level gauge and other various fields.

SPECIFICATION 1

Fluid:

Gas or Liquid

Operating condition:

Under the normal condition, where there is no inflammable gas or liquid which cause the ignition or explosion.

Type:

Cable type (With 2 m shielded cable)

Connection:

Screw connection type R1/4(PT)

Tube connection type (Size :3DIA., 8DIA., 12DIA.)

Wetted parts material:

Element Alumina
[Teflon(FEP)coating]

Sensing part Teflon(PTFE)

Packing Fluorine rubber(FPM)

Pressure range:

0 ~ 2kPa → 0 ~ 0.5MPa (0 ~ 200mmH₂O → 0 ~ 5kgf/cm²)

-20 ~ +20 → -50 ~ +50kPa

(-2000 ~ +2000 → -5000 ~ +5000mmH₂O)

-0.1 ~ 0 → -0.1 ~ 0.3MPa (-1 ~ 0 -1 ~ 3kgf/cm²)

Max. allowable pressure:

500% of pressure range

(Max. 1MPa. Allowable pressure depends on pressure range.)

Operating temperature:

-10 ~ 80°C (Tube connection type -10 ~ 60°C)

Storage temperature:

-10 ~ 100°C (Tube connection type -10 ~ 80°C)

Power source:

24V DC±10% (2 wire system)

12 ~ 30V DC (3 wire system)

Output:

4 ~ 20mA DC (2 wire system)

1 ~ 5V DC (3 wire system)

Load resistance:

500Ω max. (Current output)

10kΩ min. (Voltage output)

Consumption electric current:

15 mA or less (3 wire system)

Transmission system:

2 or 3 wire system

Accuracy:

±1.0%F.S.

Temperature coefficient:

±0.05%F.S./°C (Zero)

±0.05%F.S./°C (Span)

Construction:

Indoor use

Weight:

Pressure range 10kPa or less

Approx. 320 g (Screw connection type)

Pressure range 20kPa over

Approx. 190 g (Screw connection type)

Approx. 230 g (3 DIA. tube connection type)

Approx. 250 g (8 DIA. tube connection type)

Approx. 270 g (12 DIA. tube connection type)

SPECIFICATION 2

Allowable pressure range:

Pressure range	Allowable pressure range
0~2kPa	0.05MPa
0~5kPa 0~10kPa	0.1MPa
0~20kPa 20~+20kPa	20kPa~0.1MPa
0~50kPa	50kPa~0.2MPa
50~+50kPa 50~0kPa	50kPa~0.25MPa
0~0.1MPa 0.1~0.1MPa 0.1~0MPa	-0.1MPa~0.5MPa
0~0.2MPa 0~0.3MPa 0~0.5MPa 0.1~0.2MPa 0.1~0.3MPa	-0.1MPa~1MPa

STRUCTURAL DRAWING

Pressure is detected as static capacitance and the pressure detecting parts is a ceramic diaphragm coated with Teflon. So, the construction is of high pressure resistance and corrosion resistance type.

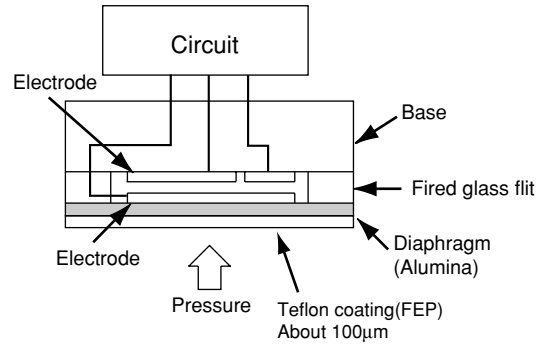

DIMENSIONS

[Screw connection type]

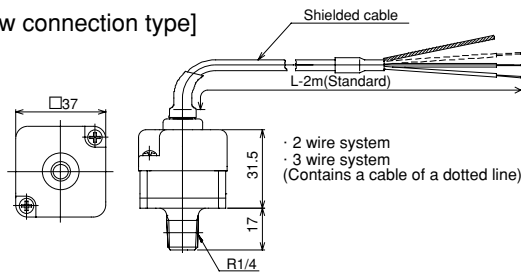

0~2, 5, 10kPa range

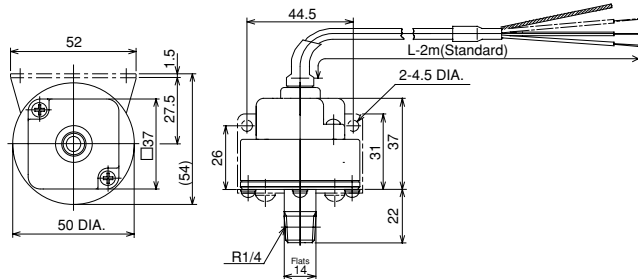

[Tube connection type]

Applicable tube size= 3 x 2mm
(Major diameter of external thread) (Bore)

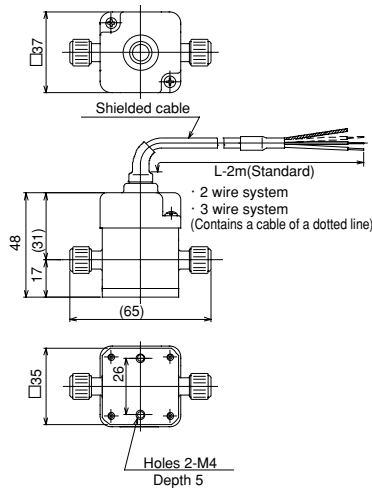

Applicable tube size= 8 x 6mm
(Major diameter of external thread) (Bore)

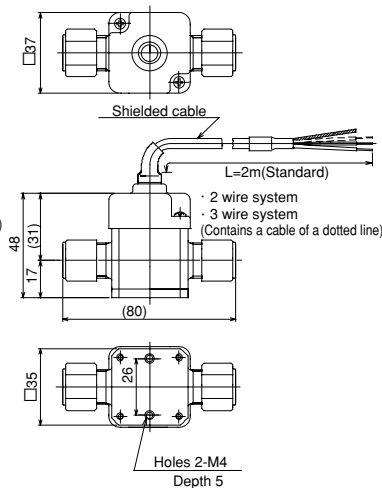

Applicable tube size= 12 x 10mm
(Major diameter of external thread) (Bore)

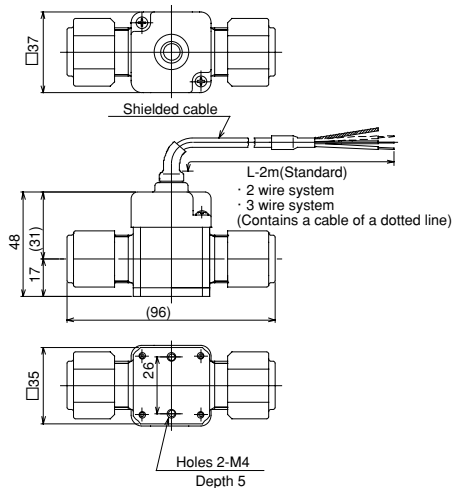

The tube connection type is SUPER FITTING of Nihon Pillar Co., Ltd., demonstrating excellent cleaning performance without liquid retaining.

WIRING

2 wire system (Electric current output)

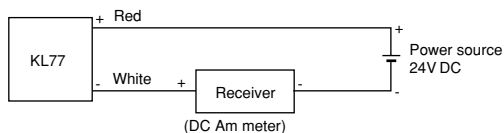

3 wire system (The voltage output)

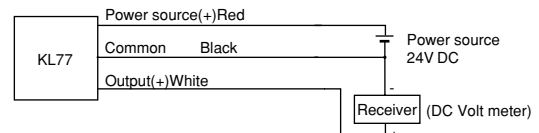

Type No. constitution

Please specify Type No.,each specification and range, when ordering.

Note: For this Model,there is no applicable item for the figures X,but please specify X when ordering.

Ceramic capacitance sensor

K L 7 7

Type No.

Slection spec.

Additional spec.(Option)

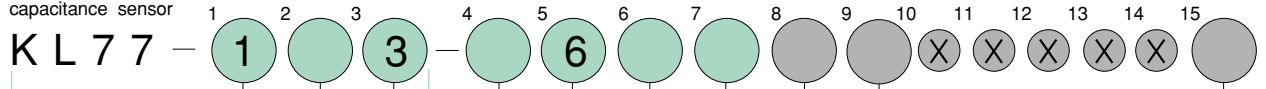

1 Type

1	Cable type (With 2 m shielded cable)
---	---

2 Connection type
(Connection, Size)

7	Screw connection type: R1/4
3	Tube connection type: 3 DIA.
8	Tube connection type: 8 DIA.
1	Tube connection type: 12 DIA.

3 Wetted parts material

3	Element:Alumina (Teflon coating) Sensing part: Teflon(PTFE) Packing: Fluorine rubber(FPM)
---	---

4 Pressure range

(When ordering,please specify pressure range & unit.)

1	0 ~ 2, 5, 10kPa
3	0 ~ 20, 50kPa
4	0 ~ 0.1, 0.2, 0.3, 0.5MPa
5	-50 ~ 0kPa, -0.1 ~ 0MPa
6	-20 ~ +20, -50 ~ +50kPa
7	-0.1 ~ 0.1, 0.2, 0.3MPa

5 Accuracy

6	±1.0%F.S.
---	-----------

6 Power source

1	24V DC±10% [2 wire system]
9	Other (12 ~ 30V DC) [3 wire system]

7 Output

1	4 ~ 20mA DC [2 wire system]
8	1 ~ 5V DC [3 wire system]

8 Treatment

0	Nil
1	Use no oil
2	Use no water
3	Use no oil & water

9 Other additional spec.

0	Nil
1	Please specify your requirement Bracket (2-10 kPa use)

15 Document

0	Nil
1	Please specify your requirement Drawing one sheet,Instruction manual, Inspection procedure,Mill sheet, Test report