

DG87

Differential Pressure Gauges

OUTLINE

This is a differential pressure gauge to detect the differential pressure, etc. due to the pressure losses of an air conditioning filter, being applied to extremely low pressure measuring. Because of the edgewise type, reading is easy, this pressure gauge can be applied as a flow meter and a micropressure gauge other than a micropressure differential pressure gauge.

FEATURES

- Small hysteresis silicone rubber is applied to the diaphragm.
- The special linkage mechanism is applied to the magnifying mechanism and the move transmitting mechanism, demonstrating high vibration resistance and durability.
- Even when the differential pressure becomes excessive, the safety mechanism has been applied to avoid damage to the moving portions.
- Zero adjustment from the outside is possible.
- This gauge is of small and light weight type.

SPECIFICATION

Fluid:

Air or non-corrosive gas

Construction:

Case sealed type

Mounting system:

Panel mounting (Clamp or screw)

Mounting posture:

Horizontal mounting, vertical mounting

Connection:

DIA. Barb connection

Gas contact part:

Diaphragm Silicone rubber

Case Plastic

Differential pressure range:

0 ~ 0.2 → 0 ~ 40kPa (0 ~ 20 → 0 ~ 4000mmH₂O)

Proof-pressure:

30kPa (0.3kgf/cm²)

But below 1kPa range

100kPa (1kgf/cm²)

But above 2kPa range

Case proof-pressure:

100kPa (1kgf/cm²)

Operating temperature:

-20~60℃ (But fluid should not be frozen)

Accuracy:

±5% F.S.

Weight:

Approx. 120g

DIMENSIONS

Panel mounting (Clamp)

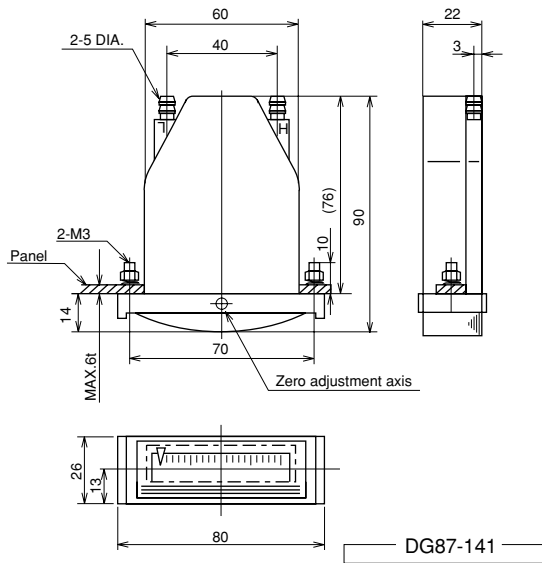

Panel mounting (Screw)

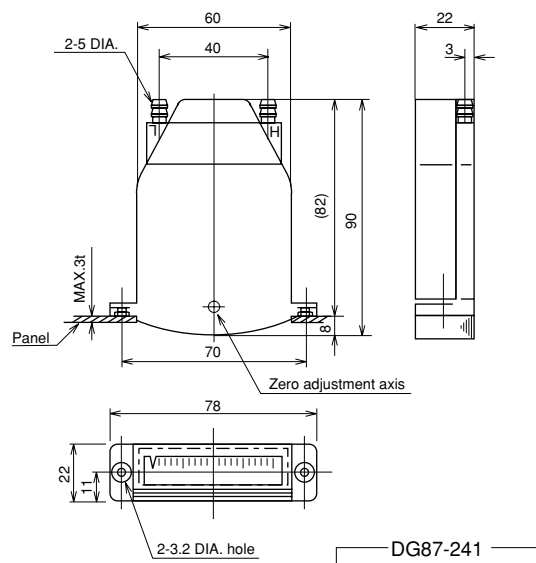

Type No. constitution

Please specify Type No., each specification and range when ordering.

Note: For this Model, there is no applicable item for the figures X, but please specify X when ordering.

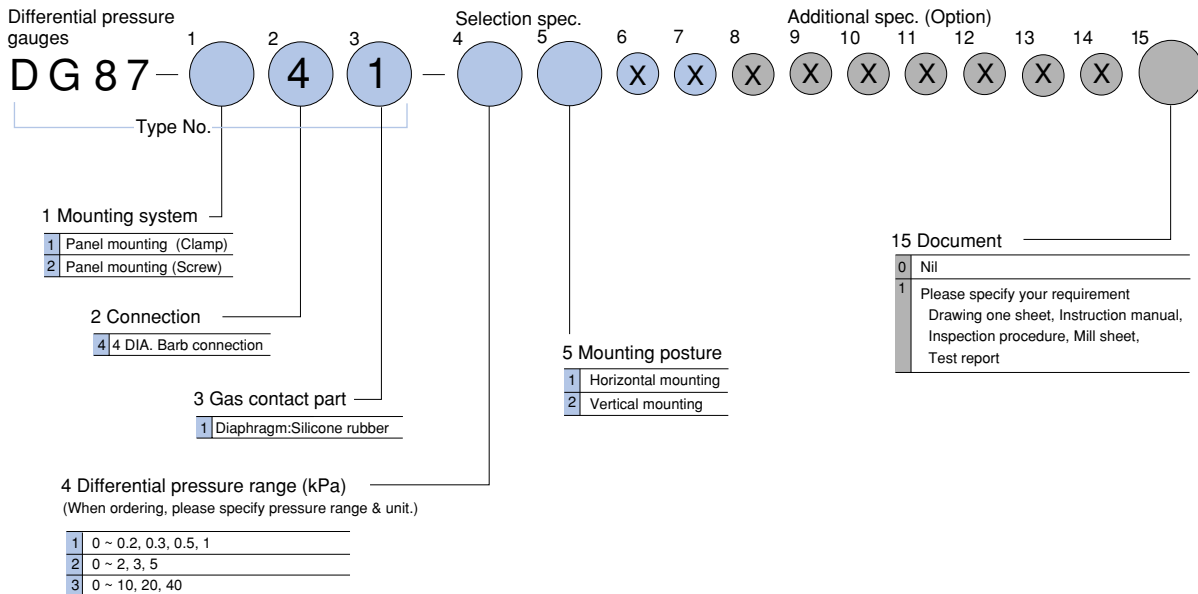

The contents in the catalogue are subject to change without notice.

NAGANO KEIKI CO., LTD.



UEDA FACTORY (JQA-0794)
 MARUKO FACTORY (JQA-0789)

HEAD OFFICE & OVERSEAS : 1-30-4, HIGASHIMAGOME OHTA-KU, TOKYO, JAPAN.
 TELEPHONE : 03 (3776) 5328
 SALES DEPT FAX : 03 (3776) 5447
 TELEX : 2468452 NKSTKY J

OVERSEAS PLANTS OR AFFILIATES: U.S.A., KOREA, GERMANY
 OVERSEAS SALES NETWORK: AUSTRALIA, HONG KONG, INDONESIA, KOREA, MALAYSIA, PHILIPPINES, SINGAPORE, TAIWAN, THAILAND, U.S.A.

