



# DG16 · 17

## Differential Pressure Gauges

### OUTLINE

This differential pressure gauge is compactly designed to measure differential pressure of 2 places. This can be used for not only measurement of differential pressure, but also measurement of tank level, loss of head of strainer or flow measurement of pipe-line by combination with orifice.

Micro switch is used for the diff. pressure gauge with electric contact and suitable for ON-OFF control.

### FEATURES

- It can bear high pressure by liquid filled in the element interior, and isn't damaged even if extreme extraneous pressure, reverse pressure acts by valve operation.
- Process pipe laying connection gets vent plug whether it is an account, and can select it in top and bottom freedom.

\* Case of demand asks for a unit of a street (kgf / cm<sup>2</sup> single dial) up to now as ordered.

### SPECIFICATION 1

#### Model:

DG16 Differential pressure gauge  
DG17 Differential pressure gauge with electric contacts

#### Fluid:

Gas or liquid

#### Operating condition:

In case of DG17, under the normal condition, where there is no inflammable gas or liquid which cause the ignition or explosion.

#### Mounting type:

2B pipe mounting, Panel mounting (DG16 only),  
Surface mounting

#### Filled liquid:

Silicone oil (General use), Daifloil (Oxygen use)

#### Size:

150 DIA.

#### Connection:

Rc1/4 (PT female), 1/4NPT female

#### Wetted parts material:

Body SCS14  
Bellows 316Lst.st.  
Gasket NBR

#### Differential pressure range:

0 ~ 20 kPa → 0 ~ 0.2 MPa (0 ~ 0.2 → 0 ~ 2 kgf/cm<sup>2</sup>)

#### Base pressure:

0 ~ 10 MPa (0 ~ 100 kgf/cm<sup>2</sup>)

#### One side pressure tight:

10 MPa (100 kgf/cm<sup>2</sup>)

#### Operating temperature:

-5 ~ 40°C (But fluid should not be frozen)

#### Indication accuracy:

±1.5%F.S. (DG17: ±3.0% F.S. at contact setting time)

#### Blowout disk:

When an emergency, Bourdon tube exploded, it open up internal pressure from blowout disk, and blowout disk prevents puncture of Window.

Note To keep normal function, please take a space behind of gauge at least 10mm when installing.  
Don't process or stop up the blowout disk.

#### Case material • finishing:

Aluminium alloy casting (AC7A) • Black

#### Valve-manifold: (Option)

Three-way valve manifold which combined the stop valve for high and low pressure and strap valve. This valve manifold is suitable for checking zero point or zero adjustment during operation and also available to prevent excess differential pressure or reversal differential pressure.

Type No.: FV43-99, FV43-993

#### Dial scale specified: (Option)

Printed words, colored circle, customer's logo

#### Weight:

DG16 Approx. 5.2 kg ~ approx. 5.9 kg  
DG17 Approx. 6.4 kg ~ approx. 6.6 kg

## DG17 DIFFERENTIAL PRESSURE GAUGE WITH ELECTRIC CONTACT

Setting accuracy:

Within 1%F.S.

Dead band:

Fixed, within 10%F.S.

Temperature coefficient:

$\pm 0.05\%F.S./^{\circ}C$

Switch:

Micro switch

Number of contact:

One contact or two contact

Setting system:

Internal adjustment type (0 ~ 100% scale) with setting lock

Outlet for electric wire:

Conduit type PF3/4, PF1/2,  
Rc1/2, 1/2NPT

Electric characteristics:

	Rating		Withstand voltage	Insulation resistance	Load inductive
	Load resistance	Load inductive			
125V AC	5 A	2 A	1500V AC	500V DC 100M $\Omega$ over	Power factor 0.4 over (AC) Time-constant 0.7 or less (DC)
250V AC					
8V DC	1 A	—	Between terminal and case 1 minute	Between terminal and case	
14V DC					
30V DC					

## WIRING

DG17

One contact

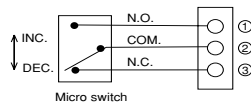

Two contact

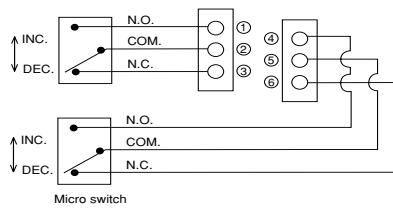

# DIMENSIONS

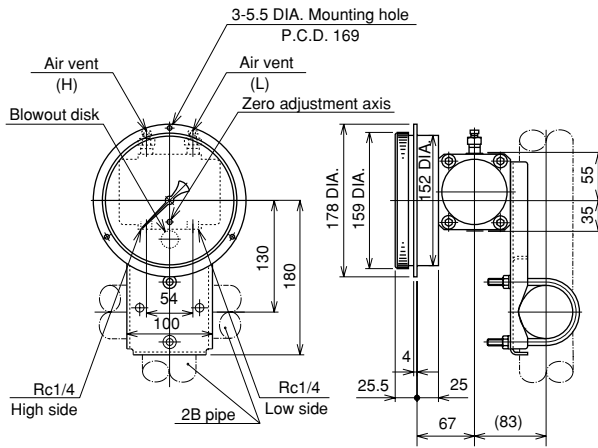

[ DG16-173 ]

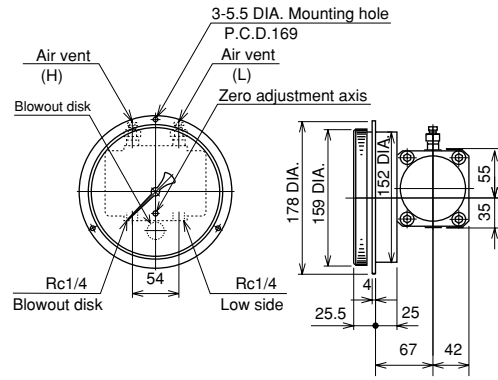

[ DG16-273 ]

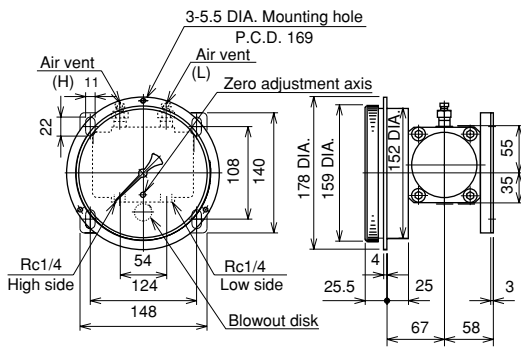

[ DG16-373 ]

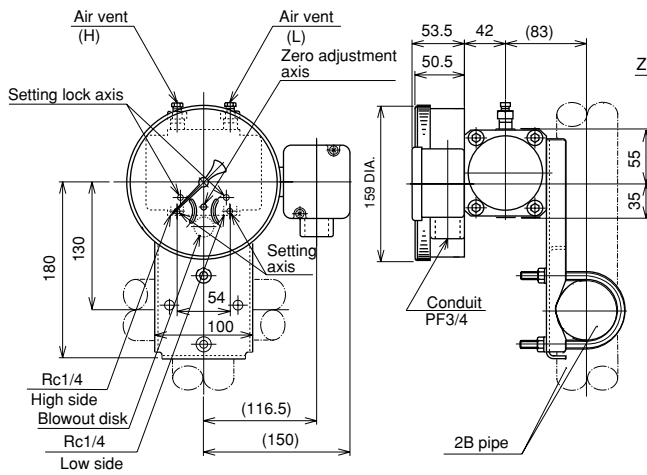

[ DG17-173 ]

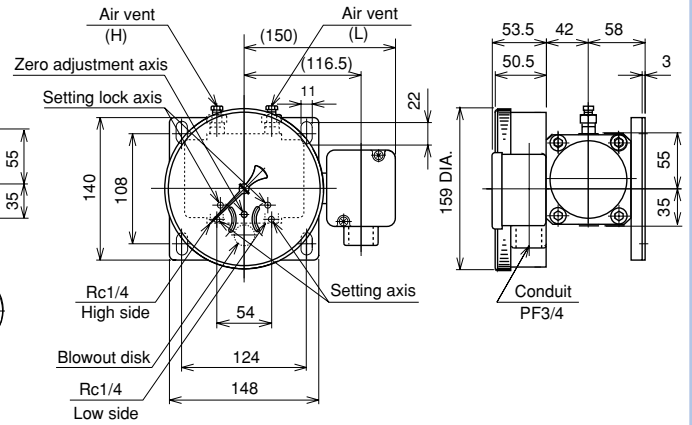

[ DG17-373 ]

Valve-manifold: (Option)

Type No.: FV43-9□

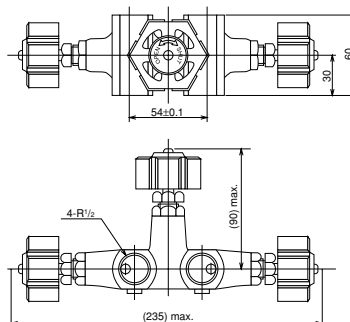

\* As for connection of differential pressure gauge and valve-manifold, FJ92-001(2 pieces) is necessary.

# Type No. constitution

Please specify Type No., each specification and range, when ordering.

Note: For this Model, there is no applicable item for the figures X, but please specify X when ordering.

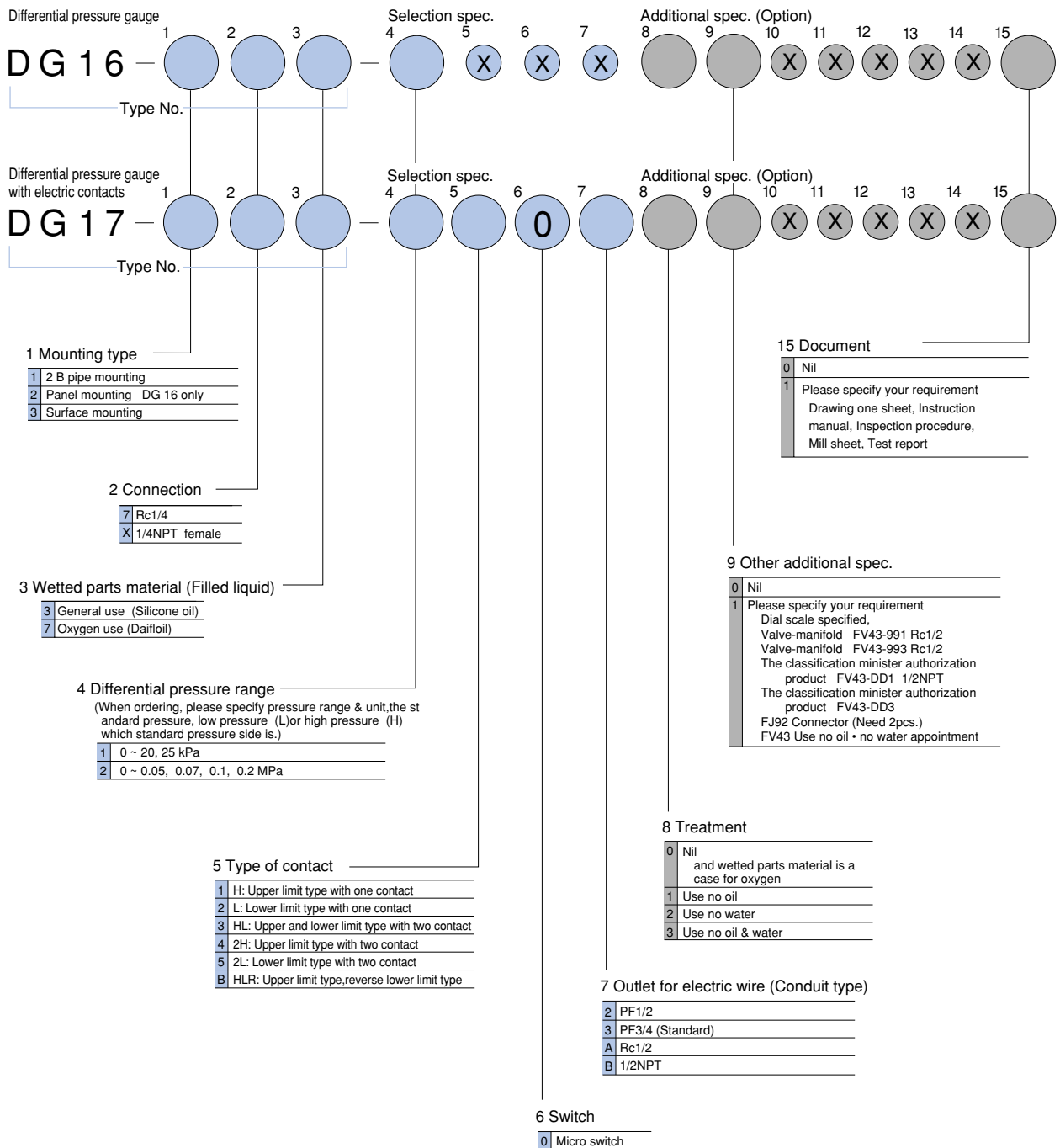

The contents in the catalogue are subject to change without notice.

**NAGANO KEIKI CO., LTD.**



UEDA FACTORY (JQA-0794)  
 MARUKO FACTORY (JQA-0789)

HEAD OFFICE & OVERSEAS SALES DEPT : 1-30-4, HIGASHIMAGOME OHTA-KU, TOKYO, JAPAN.  
 TELEPHONE : 03 (3776) 5328  
 FAX : 03 (3776) 5447  
 TELEX : 2468452 NKSTKY J

OVERSEAS PLANTS OR AFFILIATES: U.S.A., KOREA, GERMANY  
 OVERSEAS SALES NETWORK: AUSTRALIA, HONG KONG, INDONESIA, KOREA, MALAYSIA, PHILIPPINES, SINGAPORE, TAIWAN, THAILAND, U.S.A.

